

# Spec Mix D2W Workhorse Continuous Mix System

3A5646A

EN

*Electric continuous mixer for water-based cementitious materials. For professional use only.*

*Not approved for use in explosive atmospheres or hazardous locations.*

## Model 25D900

*100 psi (0.69 MPa, 6.9 bar) Maximum Water Inlet Pressure*



### Important Safety Instructions

Read all warnings and instructions in this manual. Save these instructions.

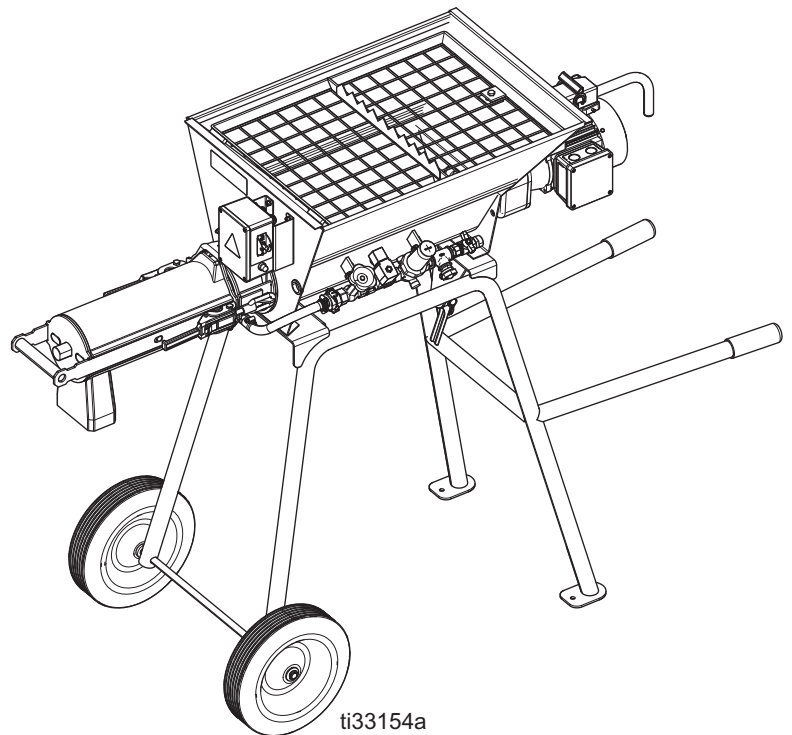

# Contents







<b>Warnings</b> .....	<b>3</b>	Disposal .....	16
<b>Component Identification</b> .....	<b>5</b>	<b>Troubleshooting</b> .....	<b>17</b>
Mix-head Assembly .....	6	<b>Schematics</b> .....	<b>19</b>
Water Control Assembly .....	6	Mixing Shaft Factory Configuration .....	20
<b>Setup</b> .....	<b>7</b>	<b>Parts</b> .....	<b>22</b>
Assemble Unit .....	7	Mixer Assembly .....	22
Prepare Unit for Operation .....	8	Cart (25D938) .....	24
Water Connections .....	9	Mixing Shaft Assembly (17T457) .....	25
Electrical Components .....	10	Water Control Assembly (17T350) .....	26
Grounding .....	10	Control Box Assembly (17T351) .....	27
<b>Operation</b> .....	<b>11</b>	<b>Dimensions</b> .....	<b>28</b>
Shutdown .....	12	<b>Technical Specifications</b> .....	<b>29</b>
Changing Material and Storing Equipment .....	14	<b>Graco Standard Warranty</b> .....	<b>30</b>
Remove Mixer from Cart Stand .....	15		
<b>Maintenance</b> .....	<b>16</b>		
Preventive Maintenance Schedule .....	16		

# Accessories







Part	Description
17T019	ACCESSORY, lid, hopper

# Warnings

The following warnings are for the setup, use, grounding, maintenance, and repair of this equipment. The exclamation point symbol alerts you to a general warning and the hazard symbols refer to procedure-specific risks. When these symbols appear in the body of this manual or on warning labels, refer back to these Warnings. Product-specific hazard symbols and warnings not covered in this section may appear throughout the body of this manual where applicable.

 <h2 style="margin: 0;">WARNING</h2>	
   	<p><b>MOVING PARTS HAZARD</b></p> <p>Moving parts can pinch, cut or amputate fingers and other body parts.</p> <ul style="list-style-type: none"> <li>• Keep clear of moving parts.</li> <li>• Do not operate equipment with protective guards or covers removed.</li> <li>• Before checking, moving, or servicing equipment, relieve pressure and disconnect all power sources.</li> </ul>
 	<p><b>ELECTRIC SHOCK HAZARD</b></p> <p>This equipment must be grounded. Improper grounding, setup, or usage of the system can cause electric shock.</p> <ul style="list-style-type: none"> <li>• Turn off and disconnect power before servicing equipment.</li> <li>• Connect only to grounded electrical outlets.</li> <li>• Ensure ground prongs are intact.</li> <li>• Do not expose to rain. Store indoors.</li> <li>• All electrical wiring must be done by a qualified electrician and comply with all local codes and regulations.</li> </ul>

# **WARNING**

 	<p><b>EQUIPMENT MISUSE HAZARD</b></p> <p>Misuse can cause death or serious injury.</p> <ul style="list-style-type: none"> <li>• Do not operate the unit when fatigued or under the influence of drugs or alcohol.</li> <li>• Do not exceed the maximum working pressure or temperature rating of the lowest rated system component. See <b>Technical Specifications</b> in all equipment manuals.</li> <li>• Use fluids and solvents that are compatible with equipment wetted parts. See <b>Technical Specifications</b> in all equipment manuals. Read fluid and solvent manufacturer's warnings. For complete information about your material, request Safety Data Sheets (SDSs) from distributor or retailer.</li> <li>• Do not leave the work area while equipment is energized or under pressure.</li> <li>• Turn off all equipment and relieve pressure when equipment is not in use.</li> <li>• Check equipment daily. Repair or replace worn or damaged parts immediately with genuine manufacturer's replacement parts only.</li> <li>• Do not alter or modify equipment. Alterations or modifications may void agency approvals and create safety hazards.</li> <li>• Make sure all equipment is rated and approved for the environment in which you are using it.</li> <li>• Use equipment only for its intended purpose. Call your distributor for information.</li> <li>• Route hoses and cables away from traffic areas, sharp edges, moving parts, and hot surfaces.</li> <li>• Do not kink or over bend hoses or use hoses to pull equipment.</li> <li>• Keep children and animals away from work area.</li> <li>• Comply with all applicable safety regulations.</li> </ul>
  	<p><b>PRESSURIZED EQUIPMENT HAZARD</b></p> <p>Fluid from the equipment, leaks, or ruptured components can splash in the eyes or on skin and cause serious injury.</p> <ul style="list-style-type: none"> <li>• Relieve pressure when you stop spraying/dispersing and before cleaning, checking, or servicing equipment.</li> <li>• Tighten all fluid connections before operating the equipment.</li> <li>• Check hoses, tubes, and couplings daily. Replace worn or damaged parts immediately.</li> </ul>
	<p><b>TOXIC FLUID OR FUMES HAZARD</b></p> <p>Toxic fluids or fumes can cause serious injury or death if splashed in the eyes or on skin, inhaled, or swallowed.</p> <ul style="list-style-type: none"> <li>• Read Safety Data Sheets (SDSs) to know the specific hazards of the fluids you are using.</li> <li>• Store hazardous fluid in approved containers, and dispose of it according to applicable guidelines.</li> </ul>
	<p><b>PERSONAL PROTECTIVE EQUIPMENT</b></p> <p>Wear appropriate protective equipment when in the work area to help prevent serious injury, including eye injury, hearing loss, inhalation of toxic fumes, and burns. Protective equipment includes but is not limited to:</p> <ul style="list-style-type: none"> <li>• Protective eyewear, and hearing protection.</li> <li>• Respirators, protective clothing, and gloves as recommended by the fluid and solvent manufacturer.</li> </ul>

# Component Identification

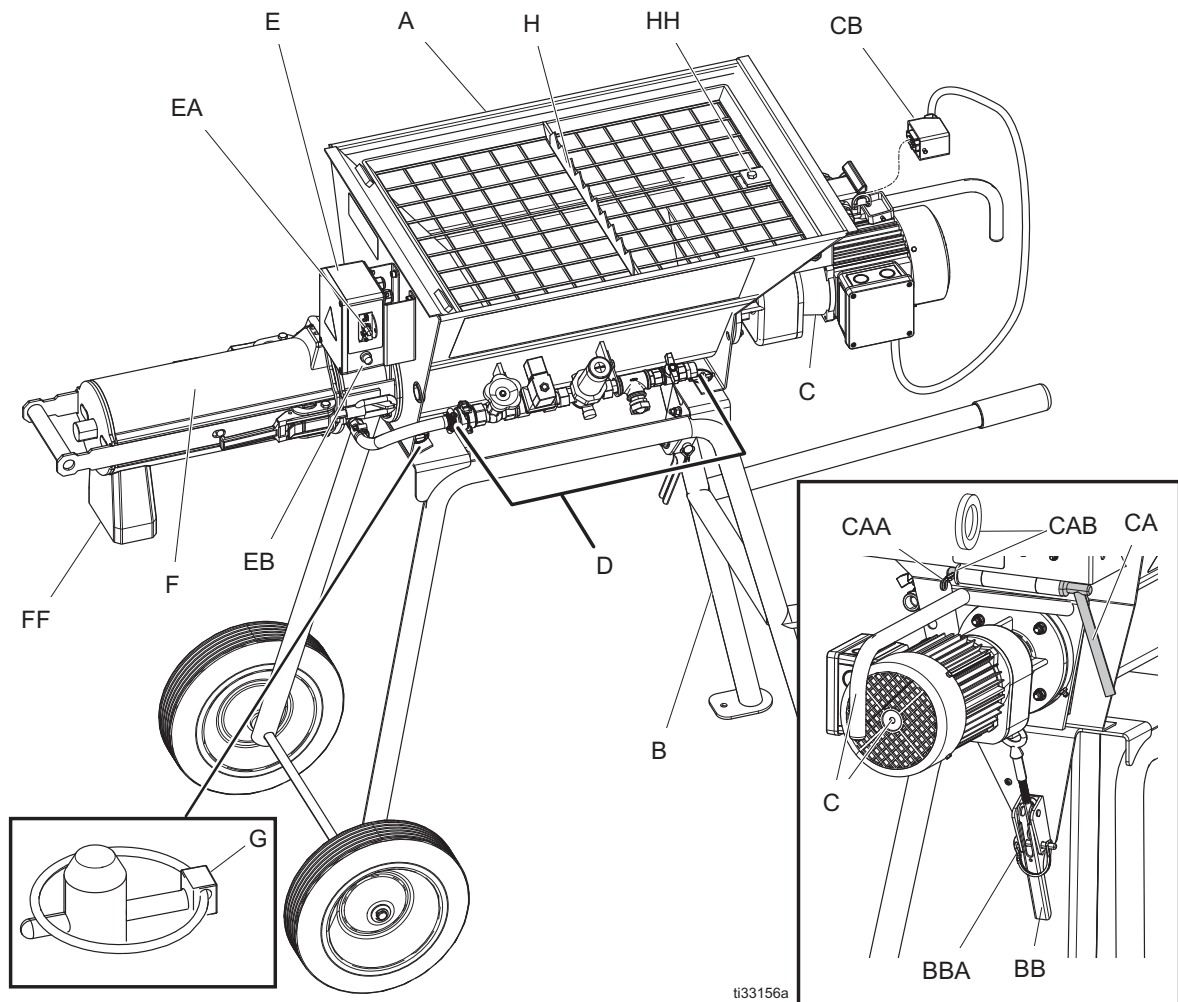

**Ref. Description**

- A Hopper
- B Cart stand
- BB Rear toggle latch
- BBA Rear toggle latch pin
- C Motor assembly
- CA Motor alignment pin
- CAA Motor alignment pin clip
- CAB Motor alignment pin washer
- CB Motor power cable
- CD Grease fitting

**Ref. Description**

- D Water control assembly  
(see detail view for components)
- E Electrical Box
- EA On/Off switch
- EB Circuit breaker reset
- F Mix-head assembly (see detail view for components)
- FF Discharge nozzle
- G Hopper ring pins
- H Hopper grate and bag breaker
- HH Grate retaining screw

## Mix-head Assembly

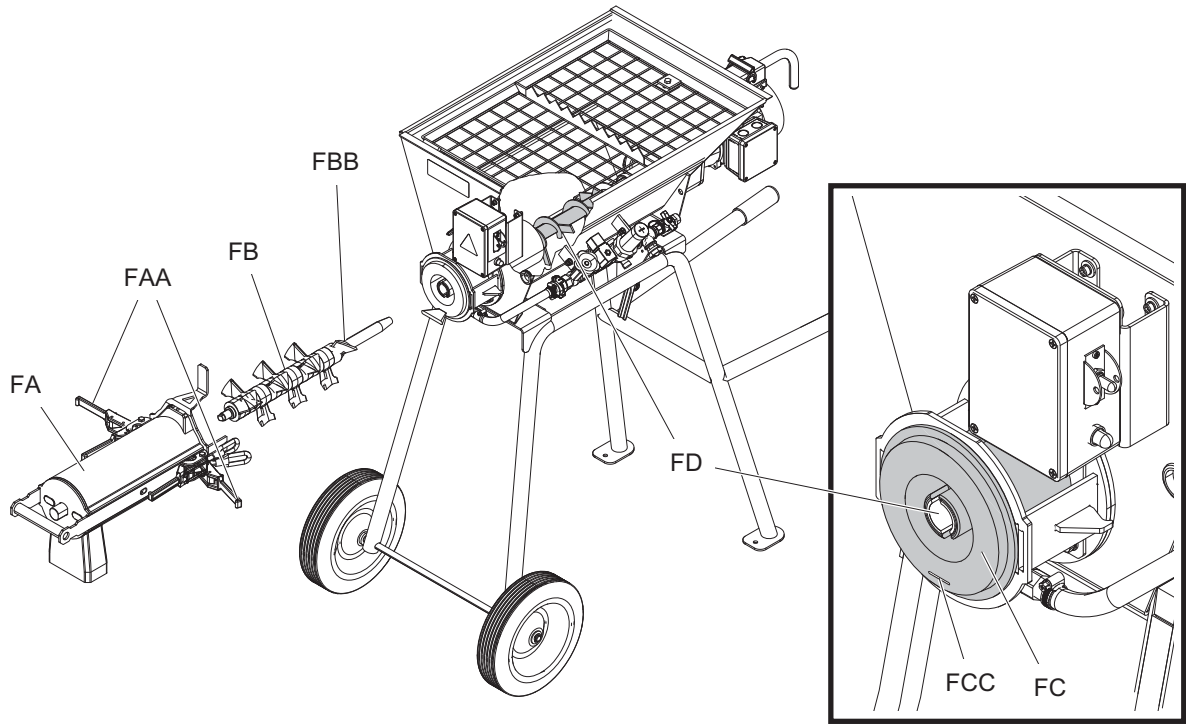

ti33157a

**Ref. Description**

- FA Mixing tube
- FAA Mixing tube toggle latches
- FB Mixing shaft
- FBB Mixing shaft pins

**Ref. Description**

- FC Throat insert
- FCC Water dosing port
- FD Material dosing auger shaft

## Water Control Assembly

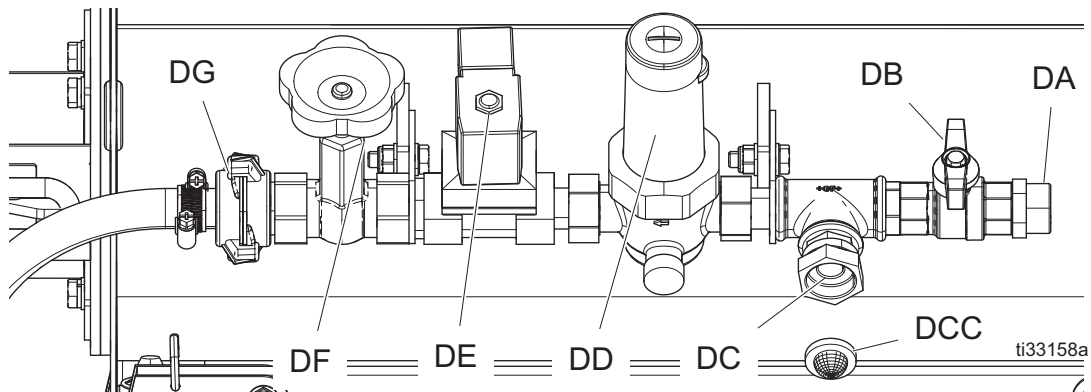

ti33158a

**Ref. Description**

- DA Water accessory fitting
- DB Water accessory shut-off ball valve
- DC Water supply inlet
- DCC Inlet screen

**Ref. Description**

- DD Water pressure regulator
- DE Water control solenoid
- DF Water metering valve
- DG Twist-claw outlet fitting/hose

# Setup

## Assemble Unit

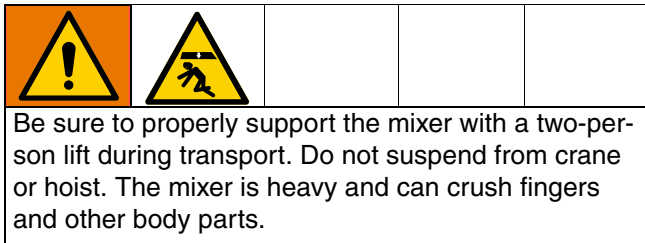
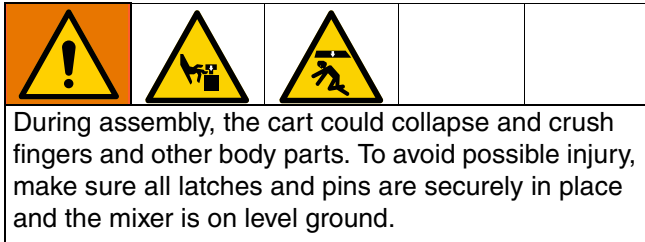

If unit is already assembled, continue to **Prepare Unit for Operation**.

1. Using a two-person lift, place the hopper (A) on top of the cart frame. Secure the hopper to all four corners of cart using the hopper ring pins (G).
2. Fully insert the material dosing auger shaft (FD) into the rear end of the hopper (A).
3. Insert mix shaft (FB) into mix tube (FA). Install shaft and tube onto hopper (A).
  - a. Align mixing shaft pins (FBB) to slots in the material dosing auger shaft (FD) and verify that pins and shaft are fully engaged.
  - b. Firmly connect mixing tube (FA) to hopper (A). Secure mixing tube toggle latches (FAA).

4. Lift the motor assembly (C) so that it connects to the material dosing auger shaft (FD). Immediately secure the motor to the hopper with the motor alignment pin (CA). Ensure the pin has slid completely into place. Slide motor alignment pin washer (CAB) over the end of the alignment pin (CA). Secure alignment pin with motor alignment pin clip (CAA).

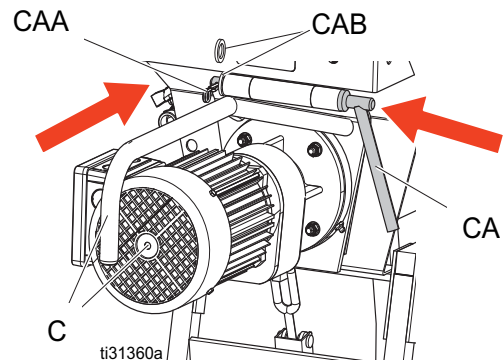

5. Engage the rear toggle latch (BB) on the rear cart leg. Secure with rear toggle latch pin (BBA).

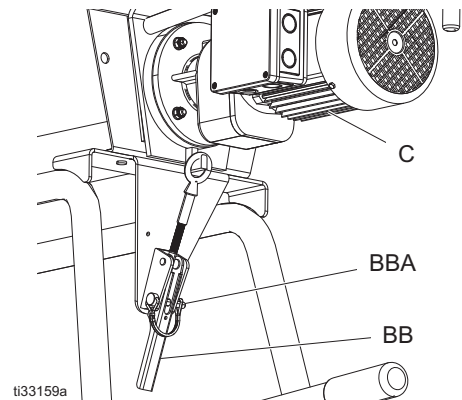

6. Connect motor power cable (CB).

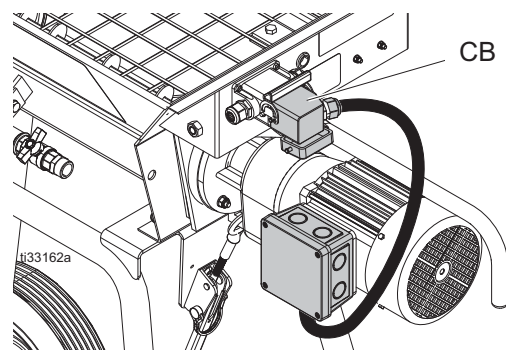

## Prepare Unit for Operation



During setup, the cart could collapse and crush fingers and other body parts. To avoid possible injury, make sure all latches and pins are in place, ensure the mixer is on level ground, and always complete steps 1 and 2 before beginning setup or moving equipment.

1. Verify that the hopper is secured to all four corners of the frame with hopper ring pins (G).

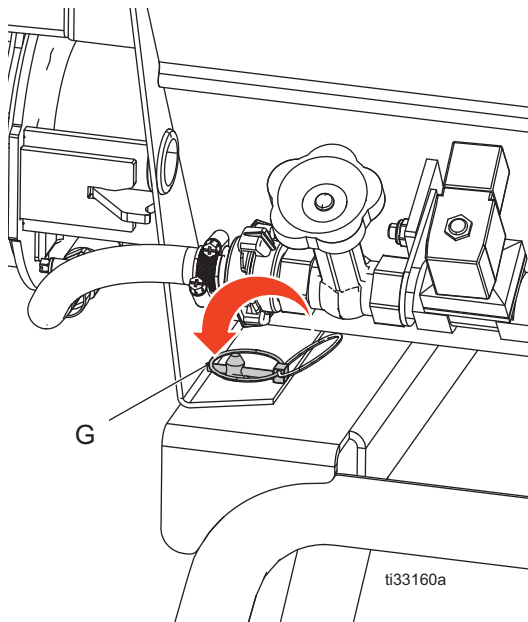

2. Verify that the motor toggle latch (BB), located on the rear cart leg, is engaged with the motor mount and secured with a rear toggle-latch pin (BBA) and frame safety pin (BA).

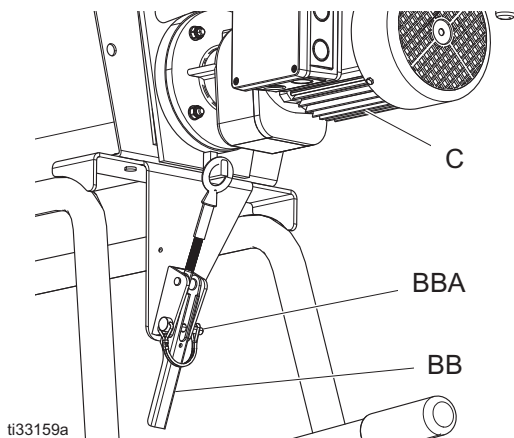

3. Verify that the motor (C) is securely mounted. The motor alignment pin (CA) must be installed and secured with a motor alignment pin washer (CAB) and motor alignment pin clip (CAA).

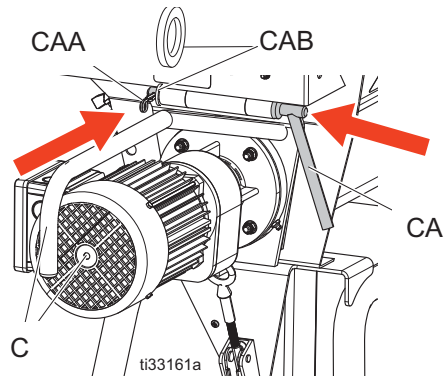

4. Verify that switch (EA) is in the off position, then connect the motor power cable (CB).

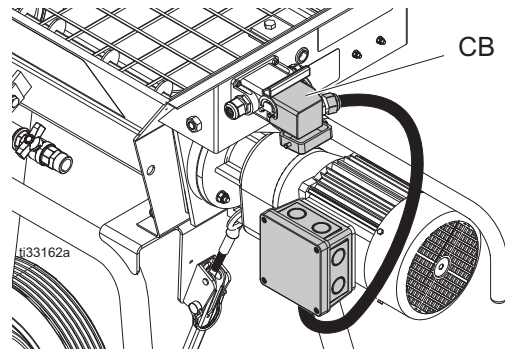

5. Verify that both mix tube toggle latches (FAA) on mixing tube (FA) are latched with their locking tabs engaged.

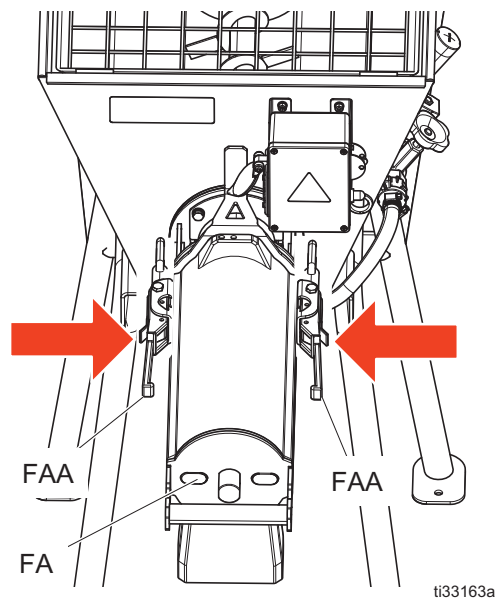



- Verify that the hopper grate (H) is installed with the bag breaker pointing up. Ensure the hopper grate is secured with the grate retaining screw (HH).

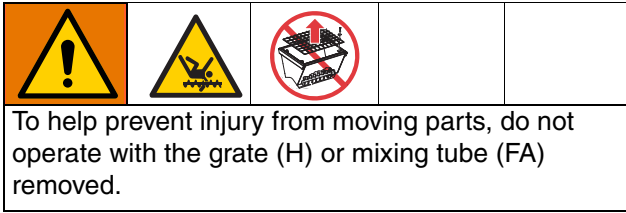

- Position the discharge nozzle (FF) of the mixer over a pump hopper, wheel barrow, or other receptacle. The mixer should always be used on a horizontal surface so it is secure and stable.

## Water Connections

- Close the water accessory shut-off ball valve (DB).

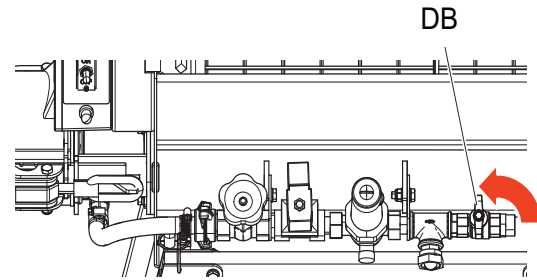

- Ensure the water supply pressure is between 30-100 psi. The water pressure regulator (DD) has been preset to 30 psi and does not usually require adjustment.

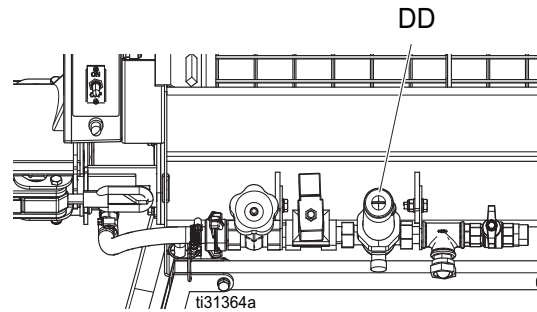

**NOTE:** The water pressure regulator (DD) reduces the supply pressure to a constant value so that the water metering valve (DF) does not need to be adjusted due to fluctuations in supply pressure. The water pressure regulator (DD) must be set below the minimum pressure expected from the water supply(s) used, and if necessary can be set down to 25 psi (1.6 bar, 0.16 MPa).

- Connect water supply hose (WH) to water supply inlet (DC).

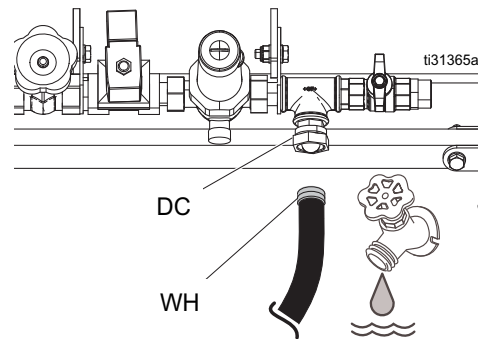

- Turn on water supply.

## Electrical Components

**NOTE:** Certain 120 V GFCI outlets have been known to trip while using this product. See **Power Supply Requirements** table.

Power Supply Requirements		
Voltage	Circuit Protection	GFCI Requirement
110-120 V	15 A Circuit Breaker	GFCI Not Recommended

Minimal Power Cord Wire Gauge	
Length (ft)	Wire Gauge (AWG)
25	16
50	12
100	10

1. Only use a grounded power cord. Plug the cord into the wall outlet.
2. Verify that the On/Off switch (EA) is in the OFF position. Plug the power cord (PC) to the electrical box (E).

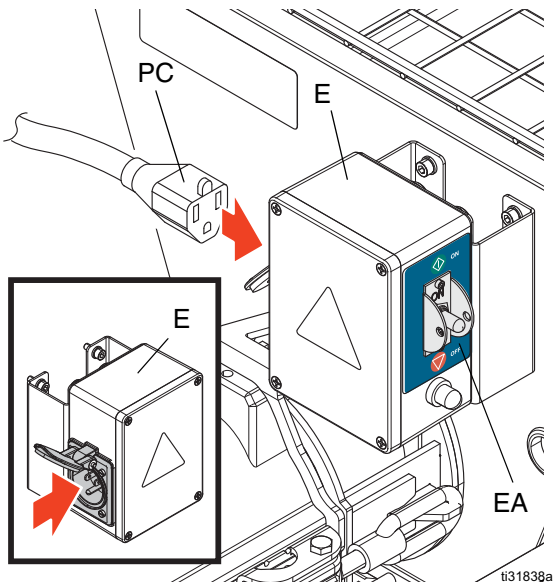

## Grounding

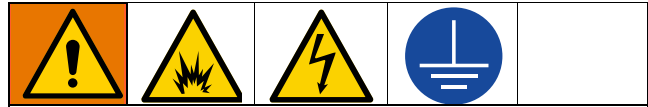



The equipment must be grounded to reduce the risk of static sparking and electric shock. Electric or static sparking can cause fumes to ignite or explode. Improper grounding can cause electric shock. Grounding provides an escape wire for the electric current.

The system is grounded through the power cord (PC).

# Operation

				
<p>To help prevent injury from moving parts, do not operate with the grate (H) or mixing tube (FA) removed.</p>				

1. Complete **Setup**, page 7.
2. Fill the hopper (A) with dry material.

				
<p>Adding material to the hopper generates clouds of dust and exposes the user to the sharp teeth on the hopper grate (H). Always wear protective equipment when adding material to the hopper.</p>				

Set the bag in the center of the hopper grate (H) so the bag breaker teeth engage the center of the bag. Twist the bag approximately 15 degrees in both directions to rip the bag open. Lift both ends of the bag so the dry materials falls out of the bag and into the hopper.

**NOTE:** Keep hopper level as close to the grate as possible to achieve maximum output and consistent water content.

3. Turn the unit on by moving switch (EA) into the ON position.

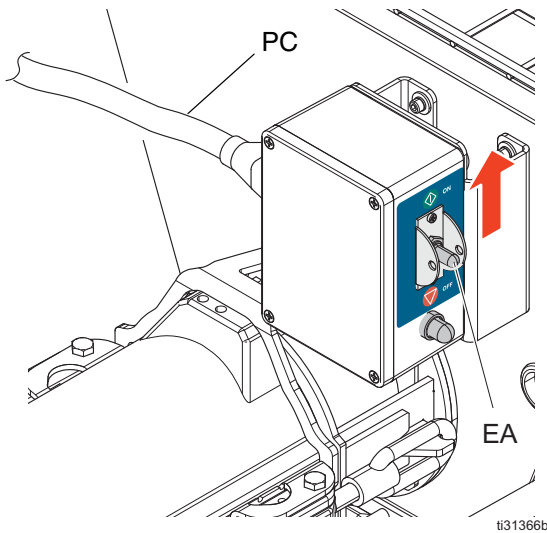

**NOTE:** The water control solenoid (DE) will automatically open when the unit is turned on.

4. Adjust the water metering valve (DF) until the material is the correct consistency.

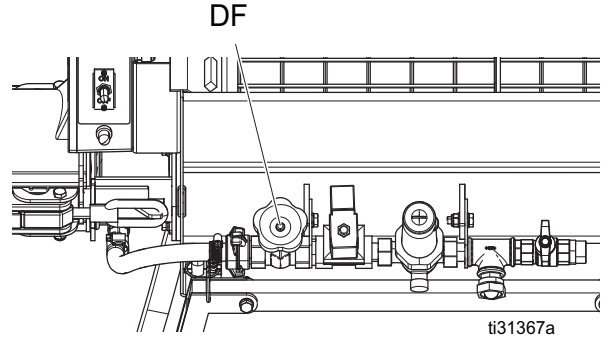

**NOTE:** It takes time for the mixed material to travel through the tube. Avoid making over-adjustments. Make small adjustments and wait 10-15 seconds to allow the material to travel through the tube before making another adjustment.

5. If desired, pause the output during operation by starting and stopping the unit using the On/Off switch (EA).

<b>NOTICE</b>
<p>To prevent damage to mix-head assembly, do not allow material to cure in mix-head assembly. Follow <b>Shutdown</b>, page 12.</p>

## Shutdown



Avoid contact with the discharge nozzle (FF), mix shaft (FB), and material dosing auger shaft (FD) during shut down. These parts can pull in, crush, cut, or amputate fingers and other body parts.

1. Let the hopper run out of dry material.
2. Turn off the water supply while mixer is running to relieve pressure.
3. Turn the unit off by flipping the switch to the OFF position.

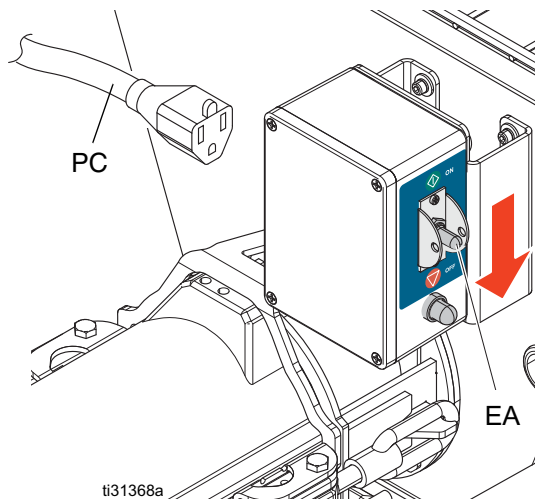

4. Unplug the power cord (PC) from the mixer.
5. Depressurize/drain water control assembly (D) by opening water accessory ball valve.

### NOTICE

To prevent damage to the water control assembly (D), drain water from unit if it is to be stored for extended periods of time or in freezing temperatures. Follow **Changing Material and Storing Equipment**, page 14.

6. Disconnect water supply.
7. Disconnect the motor power cable (CB).

### NOTICE

To prevent damage to mix-head assembly, do not allow material to cure in mix-head assembly.

8. Disengage both mix tube toggle latches (FAA) and remove mix-head assembly (F).



Do not use pressurized water jets to clean electrical box, motor, capacitors, or wires. Use of pressurized water jets can cause water to enter the electrical controls and increase potential for electric shock.

9. Pull the mixing shaft (FB) out of the mixing tube (FA) and flush both with water and a brush. Make sure all of the mixing elements on the mixing shaft are clean.
10. Clean the face of the throat insert (FC).

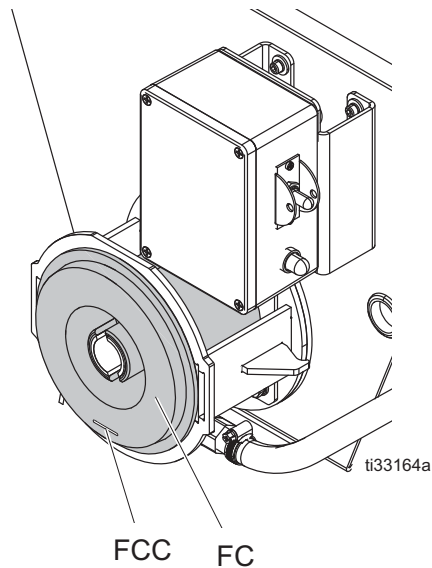



11. Clean out water dosing port (FCC).

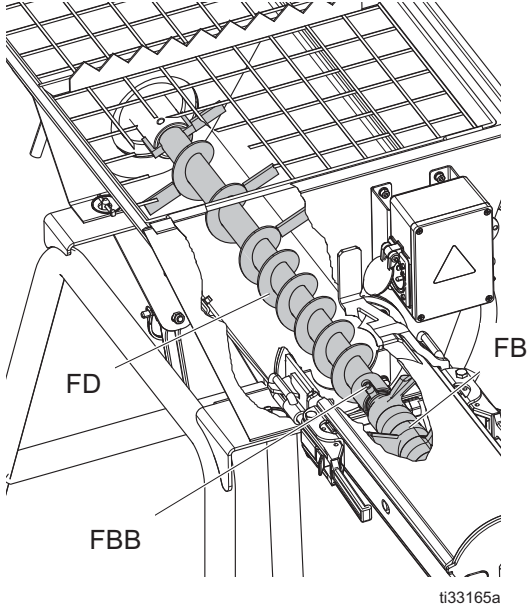

12. Reinstall the mixing tube assembly onto the throat insert. Ensure the pins (FBB) on the mixing shaft (FB) line up with the slots in the material dosing shaft (FD).

**NOTE:** Hopper lid accessory (17T019) can be used to keep excess material in hopper dry.



## Changing Material and Storing Equipment

				
<p>Avoid contact with the discharge nozzle (FF), mix shaft (FB), and material dosing auger shaft (FD) during preparation for changing material or storing equipment. These parts can pull in, crush, cut, or amputate fingers and other body parts.</p>				

				
<p>Do not use pressurized water jets to clean electrical box, motor, capacitors, or wires. Use of pressurized water jets can cause water to enter the electrical controls and increase potential for electric shock.</p>				

1. Follow **Shutdown**, page 12, steps 1-11. Do not reconnect fittings or reinstall mixing tube.
2. Vacuum and/or hose down the hopper and dosing shaft. Make sure all the dosing/breaker elements are clean.

<b>NOTICE</b>
<p>If water is used to clean hopper (A) or material dosing auger shaft (FD), allow equipment to fully dry before placing more dry material in the hopper. A wet hopper or auger shaft can cause dry material to cure onto mixer parts.</p>

3. **For storage and use in freezing temperatures:** Drain the water. Remove twist-claw irrigation fitting (DG) and open water accessory ball-valve (DB). Carefully tilt the unit to allow water to drain from both ends of the water control assembly (D), which is separated by the closed water control solenoid (DE). Ensure water has also been drained from the water output hose and water dosing port (FCC) in the throat insert (FC).

<b>NOTICE</b>
<p>If working in a cold environment, failure to drain water from the water control assembly (D) could cause damage to the system due to freezing water.</p>

4. Reconnect all fittings and reinstall the mixing tube assembly onto the throat insert. Ensure the pins (FBB) on the mixing shaft (FB) line up with the slots in the material dosing shaft (FD).

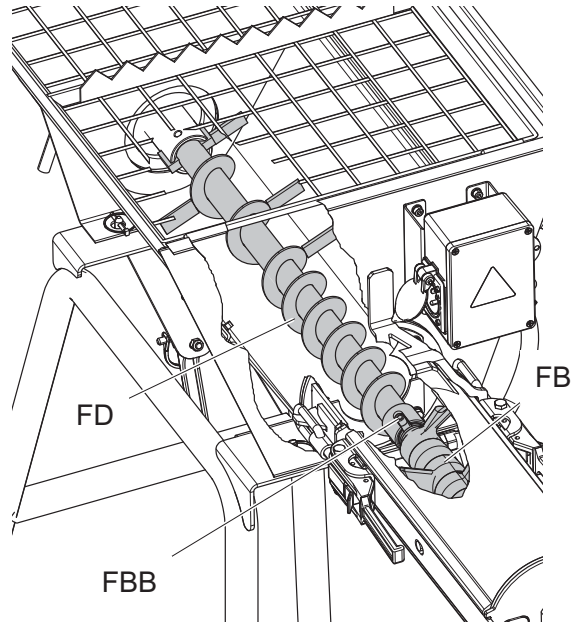



ti33165a

## Remove Mixer from Cart Stand

1. Follow the **Shutdown** procedure on page 12, then perform the **Changing Material and Storing Equipment** procedure on page 14.
2. Remove the motor:
  - a. Disconnect the motor power cable (CB).
  - b. Remove the rear toggle-latch clip (BBA), then open the rear toggle latch (BB).
  - c. Support the motor, then remove the motor alignment pin clip (CAA), motor alignment pin washer (CAB), and the motor alignment pin (CA). Set the motor aside.

3. Disengage both mixing tube toggle latches (FAA) and remove the mix-head assembly (F).
4. Remove hopper ring pins (G).
5. Remove mixer. Lift the mixer off of the stand.

				
Be sure to properly support the mixer with a two-person lift during removal. Do not suspend from crane or hoist. The mixer is heavy and can crush fingers and other body parts.				

6. For assembly, see **Assemble Unit**, page 7.

# Maintenance

## Preventive Maintenance Schedule

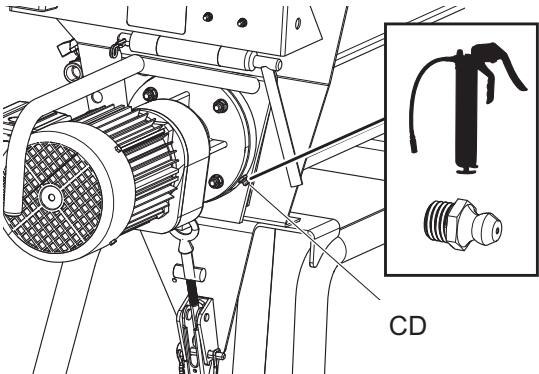
Routine Inspection		Frequency
Ensure all protective clips, ring pins, latches, grating, fasteners, housings, and enclosures are installed and in good working order, functioning properly, and free of excessive wear, cracks, or corrosion.		Before every use
Ensure all electrical components, cabling, and motor are properly assembled so that they are sealed from water ingress, free of debris, and in good working order.		
Ensure all warning labels are clean and easily readable.		
Grease		Frequency
Motor grease fitting (CD) 	Shell Gadus S2 V220 2 (formerly Shell Retinax EP2) or an equivalent NLGI Grade 2 grease compatible with rubber. Ensure any grease used is compatible. Do not mix grease types.	Monthly
Gear-box	CLP ISO VG220 gear oil or equivalent. Ensure any oil used is compatible. Do not mix oil types.	10,000 hours or 3 years (whichever comes first)

## Disposal

At the product's end-of-life, recycle the equipment in a responsible manner, per local regulations.

- Mixers contain lubricating grease in the motor coupler joint and in the gear-box. This grease may need to be flushed/drained and recycled separately from other components.



# Troubleshooting



1. Follow **Shutdown**, page 12, before checking or repairing mixer.

Problem	Cause	Solution
Poor mix quality	Mixing shaft configuration can significantly affect mix quality.	Reconfigure mixing shaft. Refer to <b>Mixing Shaft Factory Configuration</b> , page 20, for recommended configuration.
	Buildup of cured material.	Clean any debris or cured material on or inside the motor coupler, dosing auger, mix shaft, throat insert, or mix tube assembly.
Excessive wear on mix tube end cap, or mixing element at the discharge end.	The Mixing Shaft Bushing needs to be replaced.	Replace mixing shaft bushing.
	Aggregate is too large.	Refer to <b>Technical Specifications</b> , page 29, for maximum aggregate size.
Motor will not run	120 V model only: The mixer has been installed on a GFCI circuit.	Check to see if a GFCI circuit is in use and has tripped. <b>NOTE:</b> Certain 120 V GFCI outlets have been known to trip while using this product.  You may need to use a non-GFCI power supply. Refer to the <b>Power Supply Requirements</b> table, page 10, for GFCI requirements by model.
	The circuit breaker has tripped.	Reset circuit breaker switch (EB).
	Main power has turned off.	Check all cord connections are secure and voltage is correct.
	Motor power cable (CA) is disconnected.	Reconnect motor power cable (CA).
Motor stalling or, failing to get to full speed	Excessive tension/friction on the mix shaft and dosing auger.	Loosen both mix tube toggle latches (FAA). The latches are too tight if the metal frame on the mix tube bows outwards.
		Loosen the motor toggle latch if it is too tight.
		Clean any debris or cured material on or inside the motor coupler, dosing auger, mix shaft, throat insert, or mix tube assembly.
	Material in mix tube has fully or partially cured.	Follow the <b>Shutdown</b> procedure (page 12) and retry.

Problem	Cause	Solution
Material water consistency	Inlet water pressure is fluctuating below the regulator-set pressure.	The water pressure regulator (DD) reduces the pressure at the water metering valve (DF) to a constant value. Adjust the water pressure regulator (DD) so the pressure is less than the lowest pressure possible from water supply.
	Water pressure and flow is constant, but there is less dry material entering mix tube.	There is not enough dry material in the hopper. Add more dry material to the hopper, and keep adding dry material to maintain the level as close to the hopper grate as possible.
		The material dosing auger shaft (FD) is dirty or worn and needs to be cleaned or replaced.
	There is a debris in the water control assembly (D).	Verify the water inlet screen (DCC) is in place and that it is clean. Disassemble the water assembly and clean any debris. Clean debris from water dosing port (FCC).
Water does not turn on, low flow, or water does not turn off.	Solenoid damaged or clogged with debris.	Clean or replace water control solenoid (DE).
	Incorrect solenoid installed.	The solenoid must be “normally closed” type. Use only genuine Graco replacement parts.
	There is debris in the water control assembly (D).	Verify the water inlet screen (DCC) is in place and that it is clean.
	Disassemble the water control assembly (D) and clean any debris.	Clean debris from water dosing port (FCC).

# Schematics

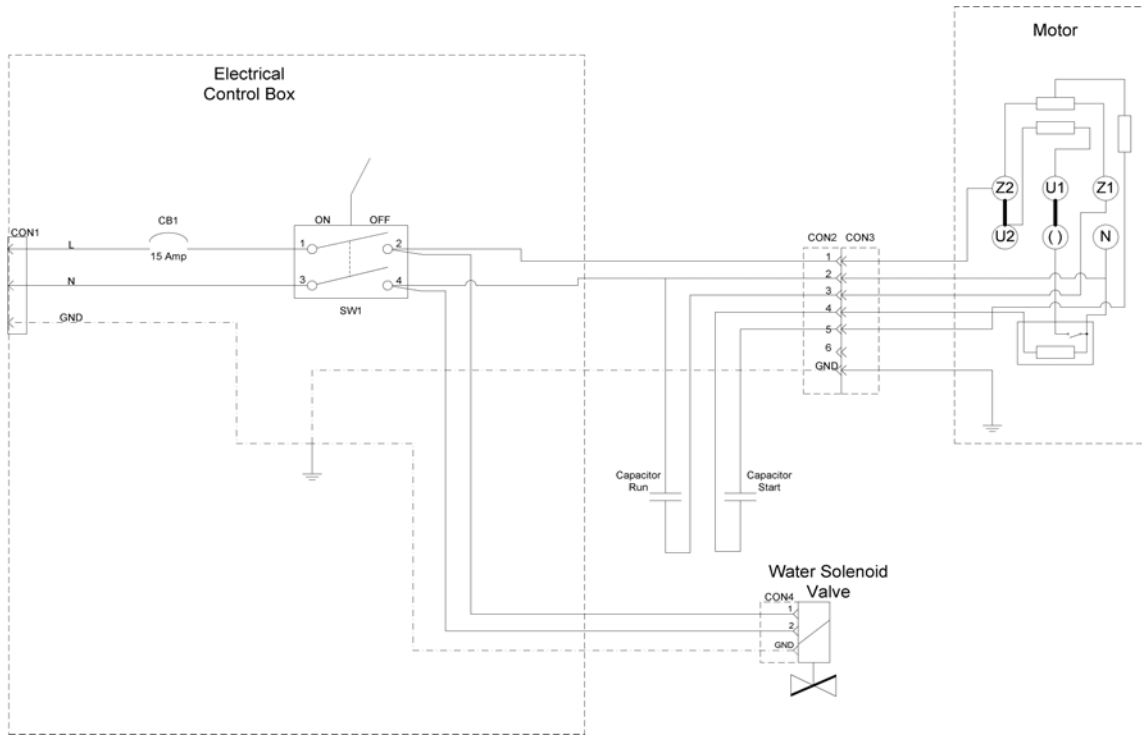

## Mixing Shaft Factory Configuration

The factory configuration of the mix shaft assembly works well for most common, pump-grade stucco materials. The configuration of the shaft can be changed if an alternate configuration is desired.

For most materials, it is recommended to reduce starting torque by positioning the pointed ends of the mixing elements so that they are on the leading edge. However, for very thin materials, positioning some or all of the mixing elements so that the blunt ends are on the leading edge may improve the mix quality.

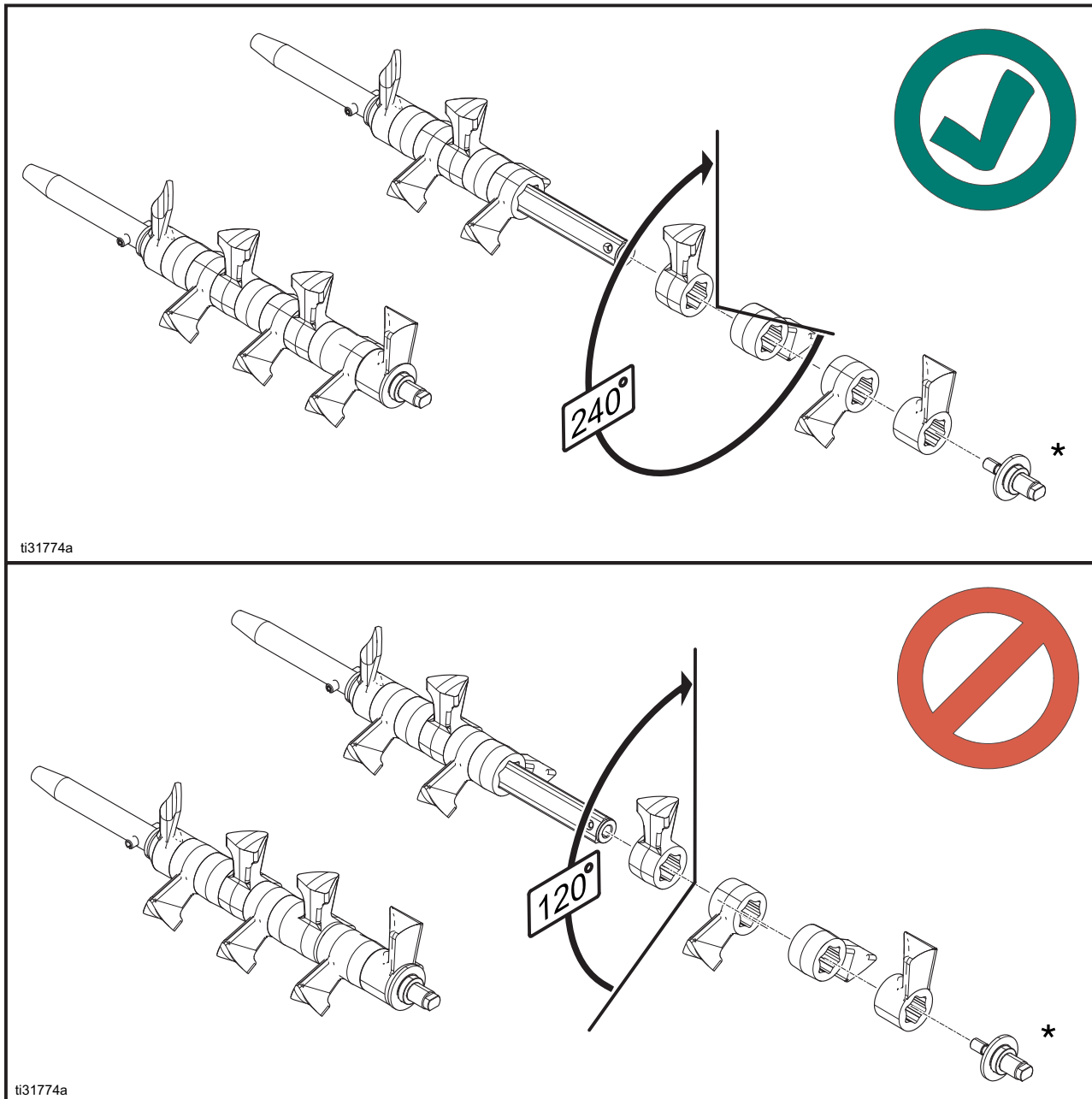

\* The mix shaft retainer has a left-handed thread to ensure it does not disassemble during operation. To loosen retainer, rotate clockwise.



# Parts

## Mixer Assembly

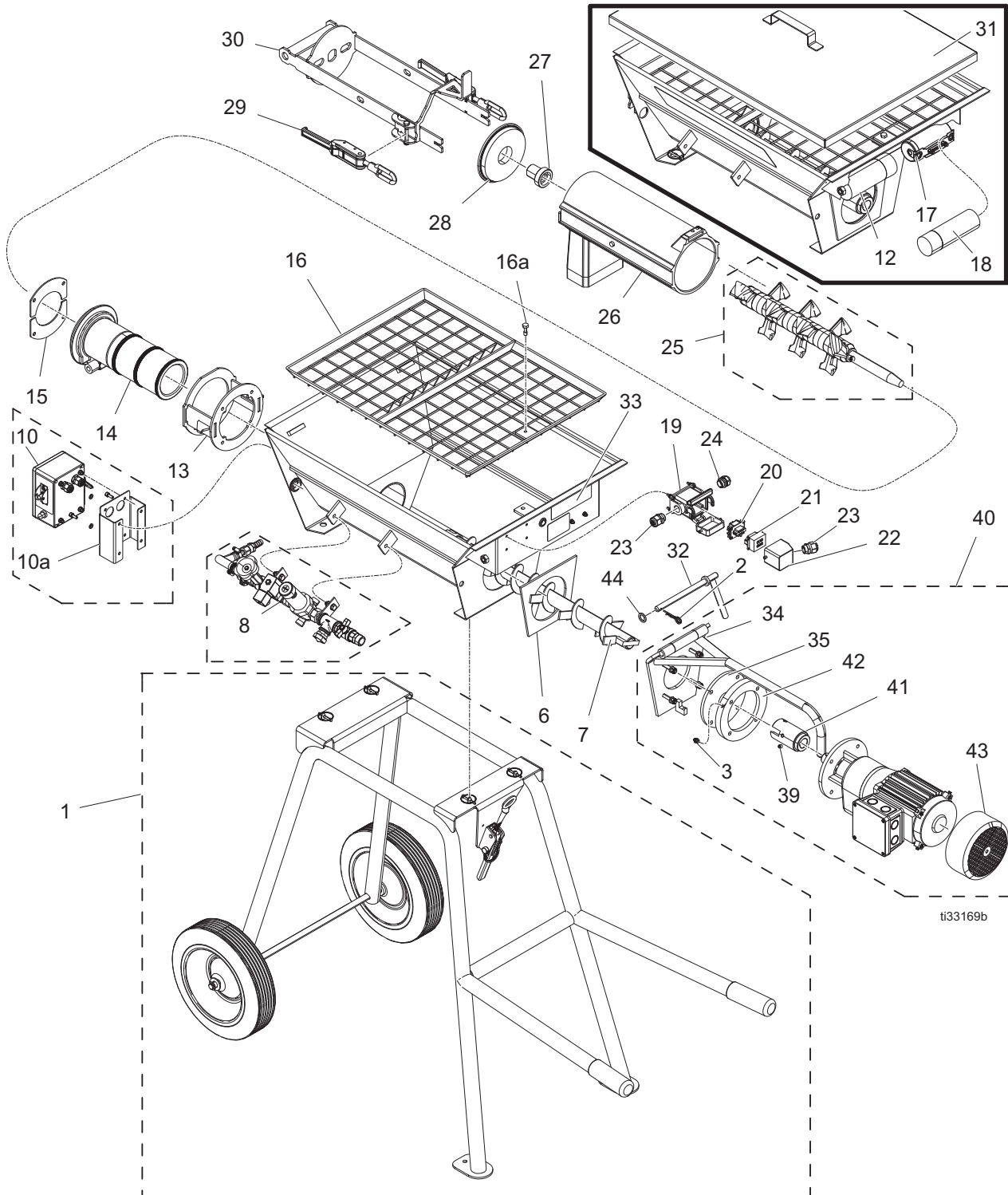

Ref.	Part	Description	Qty.
1	25D938	KIT, cart, D2W, Workhorse	1
2	17T334	KIT, clip, hitch, low profile	1
3	17T513	FITTING, grease, m8x1	1
6	17T442	KIT, gasket, hopper, motor	1
7	17T470	KIT, auger, dosing, 55 mm, black	1
8	17T350	KIT, module, water control, 120V	1
10	17T351	KIT, control box, 120V	1
10a	17T366	KIT, bracket, control box	1
12	17T349	KIT, capacitor, 80 µf, stud (run), (120 V system)	1
13	17T342	KIT, collar, mounting, mix head	1
14	17T443	KIT, insert, throat, dosing zone	1
15	17T330	KIT, plate, clamp, collar (pack of two)	2
16	17T441	KIT, grate, hopper	1
16a	17T327	KIT, fastener, captured	1
17	17T352	KIT, capacitor, 216 µf (start), (120 V system)	1
19	17T446	KIT, housing, socket, 6-pin	1
20	17T448	KIT, connector, socket, 6-pin	1
21	17T449	KIT, connector, plug, 6-pin	1
22	17T335	KIT, housing, plug, 6-pin	1
23	17T447	KIT, grip, cord	1
24	17T346	KIT, grip, cord, 2-wire	1
25	17T457	KIT, shaft, mix assembly	1
26	17T459	KIT, sleeve, mix tube	1
27	17T456	KIT, bushing, bearing, mix shaft	1
28	17T455	KIT, cap, mix tube	1
29	17T468	KIT, latch, toggle	2
30	17T458	KIT, frame, mix head	1
31	17T019	ACCESSORY, lid, hopper (not included)	1
32	17T333	KIT, pin, motor, alignment	1
33▲	17M606	LABEL, warning, entanglement	1
34	17T332	KIT, bracket, motor mount	1
35	17T445	KIT, seal, motor coupler	1
39	-----	SCREW, set, m8 x 1.25 x 10 mm	1
40	17T367	KIT, motor, 120 V/60 Hz, mounted	1
41	17T345	KIT, coupler, motor	1
42	17T339	KIT, flange, ring, motor mount	1
43	17T368	KIT, cover, motor fan, 150 mm	1
44	-----	WASHER, flat, 15 mm	1

▲ Replacement Danger and Warning labels, tags, and cards are available at no cost.

# Cart (25D938)

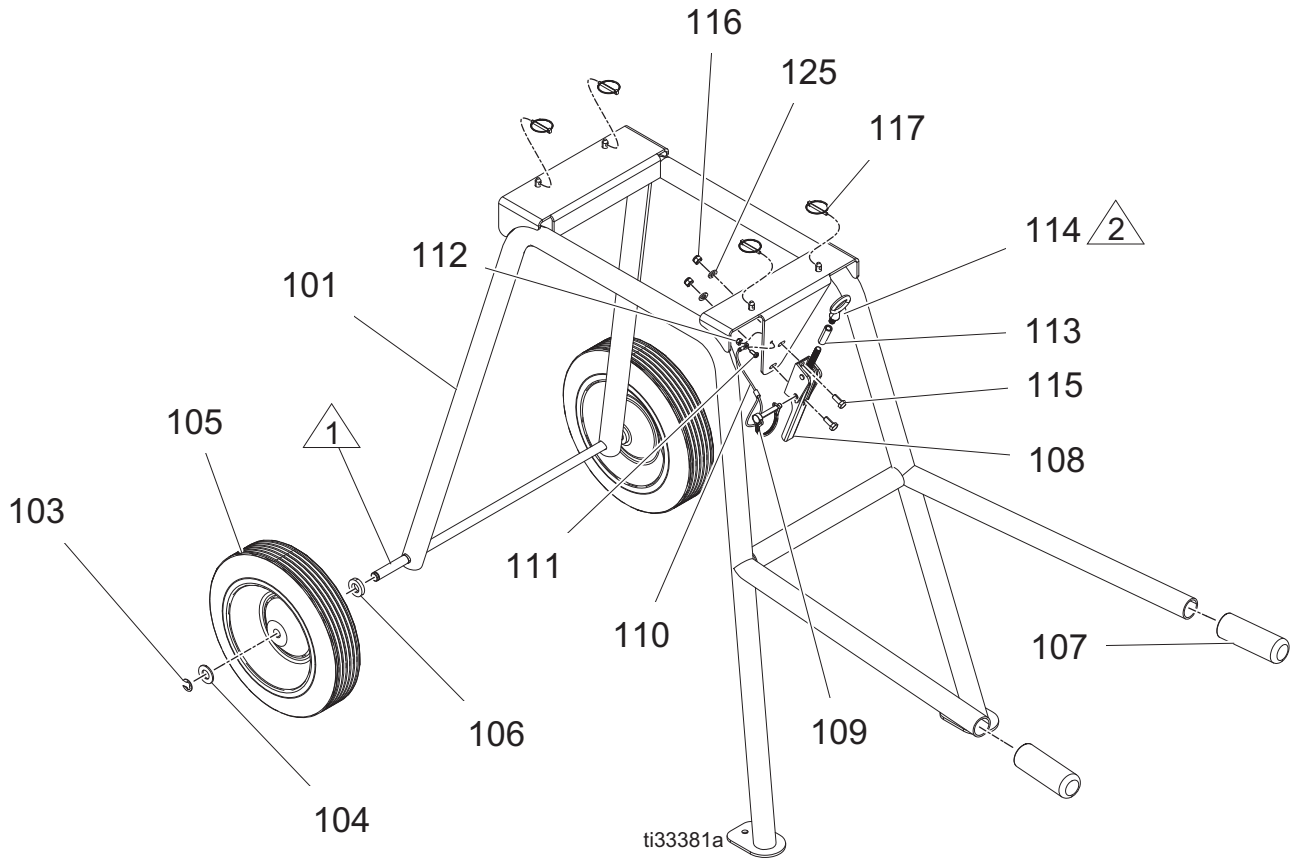

△ Lubricate axle with lithium grease.

△ Assemble with permanent (red) threadlocker.

Ref.	Part	Description	Qty.	Ref.	Part	Description	Qty.
101	----	CART, Spec Mix	1	113	17V535	ADAPTER, latch, eye bolt	1
103*	101242	RING, retaining, ext.	2	114	17V606	BOLT, eye, 3/8	1
104*	----	WASHER, plain, 5/8	2	115	125112	SCREW, cap, 5/16-18	2
105*	----	WHEEL, semi-pneumatic, offset	2	116	----	NUT, nylock, 5/16	2
106*	----	WASHER, space	2	117	MTA010	PIN, lynch, 3/16 diameter shaft	4
107	17W644	KIT, grip, cart, handle (pack of two)	2	125	----	WASHER, plain, 5/16	2
108	17J710	KIT, latch, adjustable	1				
109	17W645	KIT, pin, 5/16, locking	1				
110	17V605	CABLE, lanyard	1				
111	----	SCREW, pan, #10-24	1				
112	----	NUT, nylock, #10-24	1				

*\*Wheel Replacement Kit 17J706 (purchase separately) includes 103 (1), 104 (1), 105 (1), and 106 (1).*



# Mixing Shaft Assembly (17T457)

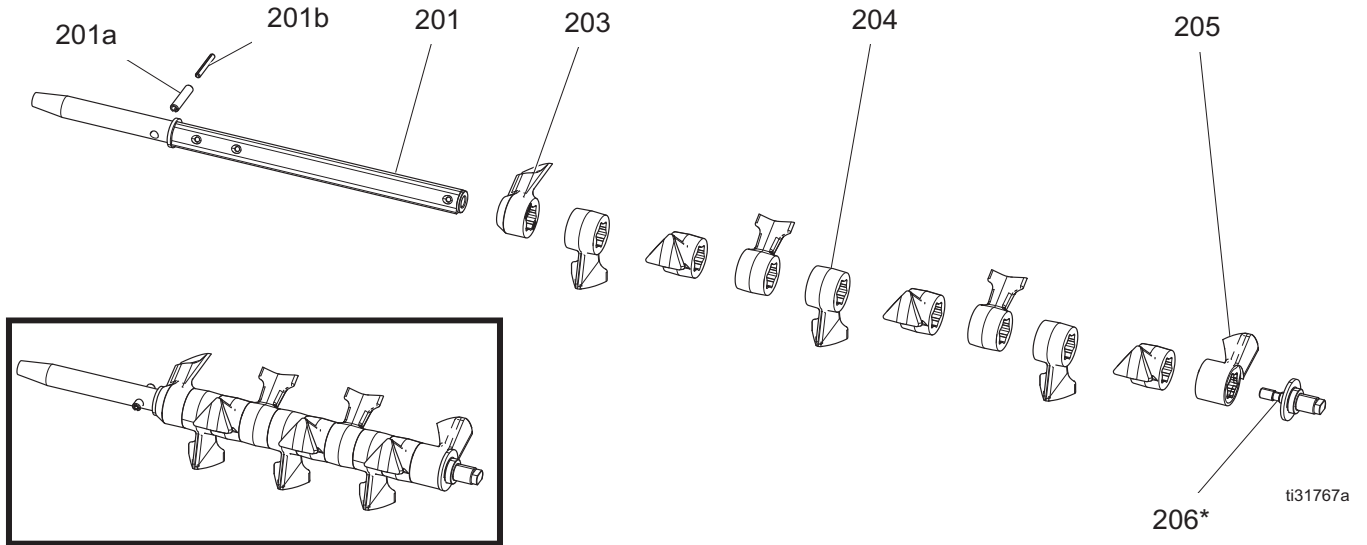

Ref.	Part	Description	Qty.
201	17T460	KIT, shaft, mix, bare	1
201a	17T464	KIT, pin, roll, 10 mm x 45 mm long	1
201b	17T465	KIT, pin, roll, 6 mm x 45 mm long	1
203	17T461	KIT, element, mix wing, inlet	1
204	17T466	KIT, element, mixing wing	8
205	17T463	KIT, element, mix wing, outlet	1
206*	17T462	KIT, retainer, mix shaft, M12 left-handed	1

\* The mix shaft retainer has a left-handed thread to ensure it does not disassemble during operation. To loosen retainer, rotate clockwise.

## Water Control Assembly (17T350)

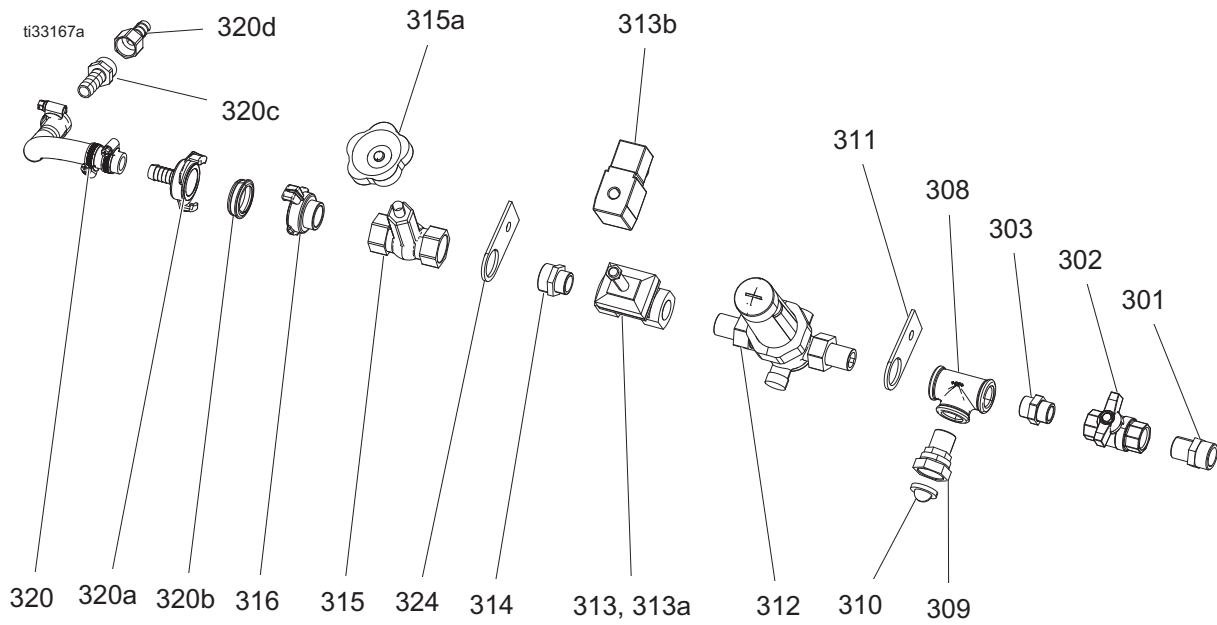

Ref.	Part	Description	Qty.
301	17T355	KIT, fitting, gh, male	1
302	17T451	KIT, valve, ball	1
303	125408	FITTING, nipple	1
308	101846	FITTING, tee, 1/2 pipe	1
309	17T354	KIT, fitting, gh, female, swivel	1
310	17T426	KIT, screen, filter, gh	1
311	17T337	KIT, bracket, wc assembly, right	1
312	17T450	KIT, regulator, pressure	1
313	17T353	KIT, solenoid, valve, 120 V	1
313b	17T357	KIT, coil, solenoid valve, 120 v	1
314	17T338	KIT, fitting, reducer, 3/4 to 1/2 pipe	1
315	17T452	KIT, valve, needle	1
315a	17T469	KIT, handle, needle valve	1
316	17T453	KIT, fitting, Geka x 3/4 in. bsp	1
320	17T340	KIT, hose, outlet assembly	1
320a	17T454	KIT, fitting, Geka x 1/2" barb	1
320b	17T438	KIT, gasket, Geka	1
320c	17T329	KIT, fitting, barb, male	1
320d	17T328	KIT, fitting, barb, female	1
324	17T336	KIT, bracket, wc assembly, left	1

## Control Box Assembly (17T351)

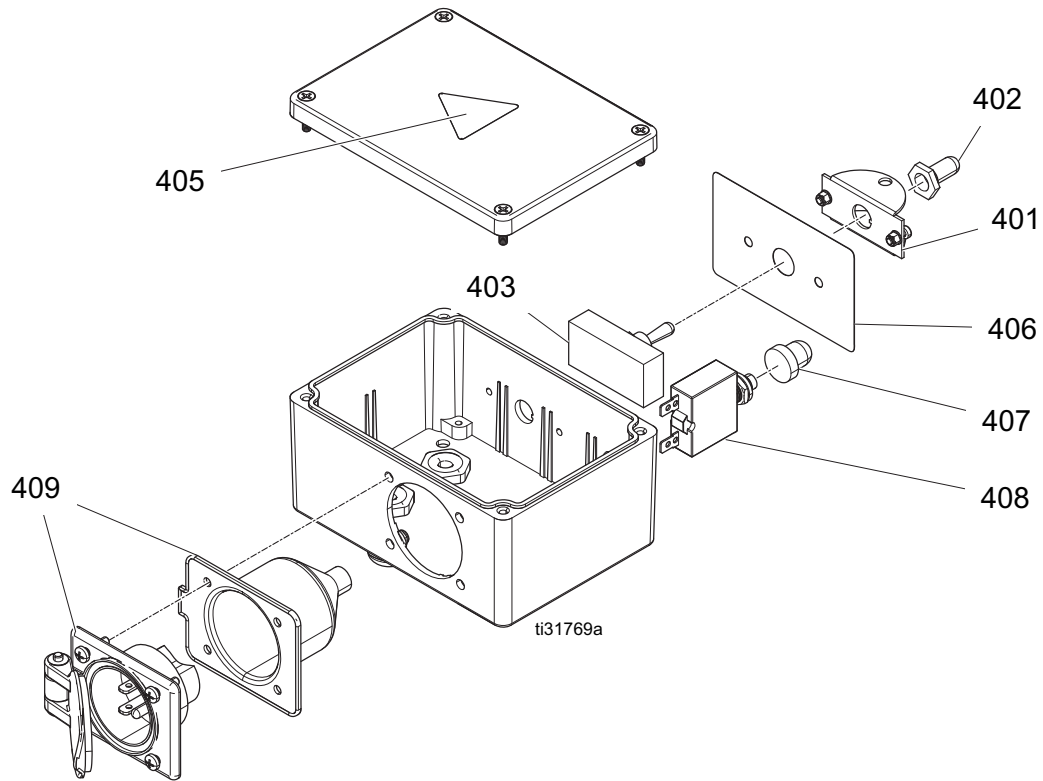

Ref.	Part	Description	Qty.
401	17T364	KIT, guard, toggle switch	1
402	17T362	KIT, boot, toggle switch	1
403	17T425	KIT, switch, toggle	1
405▲	16T764	LABEL, warning, shock	1
406	17T365	KIT, label, on-off	1
407	17T423	KIT, boot, breaker switch	1
408	17T363	KIT, circuit, breaker, 15 A/1 pole	1
409	17T360	KIT, socket, power inlet, 15 A	1

▲ Replacement Danger and Warning labels, tags, and cards are available at no cost.

# Dimensions

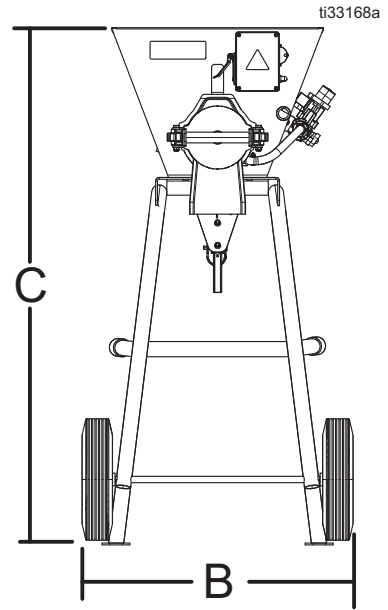
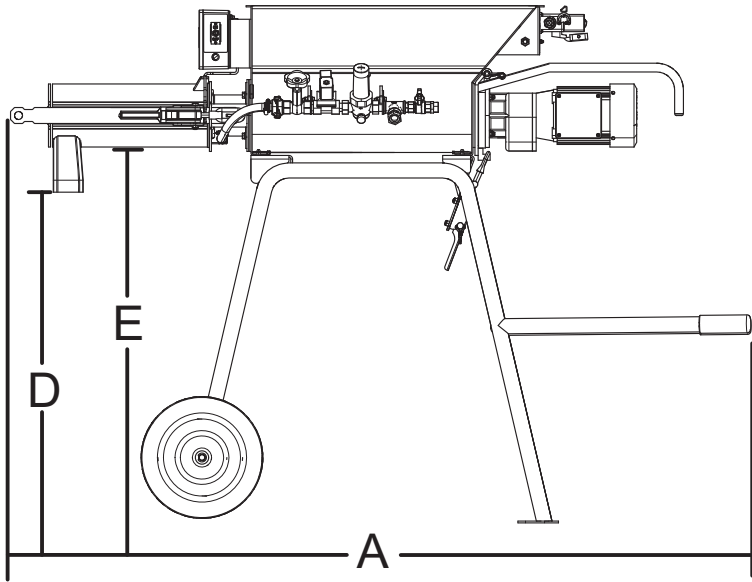

Dimensions		
	U.S.	Metric
A	73.0 in.	185 cm
B	26.7 in.	68 cm
C	51.0 in.	130 cm
D	32.0 in.	81 cm
E	36.4 in.	92 cm

# Technical Specifications

<b>Spec Mix D2W Workhorse Continuous Mix System</b>		
	<b>US</b>	<b>Metric</b>
Maximum water feed inlet pressure	100 psi	0.69 MPa, 6.9 bar
Maximum Motor Speed	260 rpm	
Output	*40 bags per hour	
Hopper Capacity	1.6 cubic ft (2.5-3 80 lb bags typical)	45 liters
Weight (empty)	216 lb	98 kg
Power Requirements	120 V / 60 Hz / 15 Amps / 1.5 hp	
<b>Materials</b>		
Water-based cementitious materials with aggregate less than 0.160 in. (4 mm) in diameter.		
<b>Water Inlet Feed Pressure Requirements</b>		
Minimum Pressure	30 psi	0.21 MPa, 2.1 bar
Maximum Pressure	100 psi	0.69 MPa, 6.9 bar
<b>Material Construction</b>		
Wetted Components	Brass, rubber, plastic, plated steel, aluminum	
<b>Noise (dBa)</b>		
Maximum sound pressure level less than 75 db(A) A-rating emission.		
<b>Inlet/Outlet Sizes</b>		
Fluid inlet size	3/4 in. garden hose thread, female swivel	
Fluid outlet size	3/4 in. garden hose thread, male swivel	
<b>Operating Ambient Temperature</b>		
Temperature	32° to 120° F	0° to 49° C

\* 80 lb bags, base coat stucco (approximately 6 gpm).

# Graco Standard Warranty

Graco warrants all equipment referenced in this document which is manufactured by Graco and bearing its name to be free from defects in material and workmanship on the date of sale to the original purchaser for use. With the exception of any special, extended, or limited warranty published by Graco, Graco will, for a period of twelve months from the date of sale, repair or replace any part of the equipment determined by Graco to be defective. This warranty applies only when the equipment is installed, operated and maintained in accordance with Graco's written recommendations.

This warranty does not cover, and Graco shall not be liable for general wear and tear, or any malfunction, damage or wear caused by faulty installation, misapplication, abrasion, corrosion, inadequate or improper maintenance, negligence, accident, tampering, or substitution of non-Graco component parts. Nor shall Graco be liable for malfunction, damage or wear caused by the incompatibility of Graco equipment with structures, accessories, equipment or materials not supplied by Graco, or the improper design, manufacture, installation, operation or maintenance of structures, accessories, equipment or materials not supplied by Graco.

This warranty is conditioned upon the prepaid return of the equipment claimed to be defective to an authorized Graco distributor for verification of the claimed defect. If the claimed defect is verified, Graco will repair or replace free of charge any defective parts. The equipment will be returned to the original purchaser transportation prepaid. If inspection of the equipment does not disclose any defect in material or workmanship, repairs will be made at a reasonable charge, which charges may include the costs of parts, labor, and transportation.

**THIS WARRANTY IS EXCLUSIVE, AND IS IN LIEU OF ANY OTHER WARRANTIES, EXPRESS OR IMPLIED, INCLUDING BUT NOT LIMITED TO WARRANTY OF MERCHANTABILITY OR WARRANTY OF FITNESS FOR A PARTICULAR PURPOSE.**

Graco's sole obligation and buyer's sole remedy for any breach of warranty shall be as set forth above. The buyer agrees that no other remedy (including, but not limited to, incidental or consequential damages for lost profits, lost sales, injury to person or property, or any other incidental or consequential loss) shall be available. Any action for breach of warranty must be brought within two (2) years of the date of sale.

**GRACO MAKES NO WARRANTY, AND DISCLAIMS ALL IMPLIED WARRANTIES OF MERCHANTABILITY AND FITNESS FOR A PARTICULAR PURPOSE, IN CONNECTION WITH ACCESSORIES, EQUIPMENT, MATERIALS OR COMPONENTS SOLD BUT NOT MANUFACTURED BY GRACO.** These items sold, but not manufactured by Graco (such as electric motors, switches, hose, etc.), are subject to the warranty, if any, of their manufacturer. Graco will provide purchaser with reasonable assistance in making any claim for breach of these warranties.

In no event will Graco be liable for indirect, incidental, special or consequential damages resulting from Graco supplying equipment hereunder, or the furnishing, performance, or use of any products or other goods sold hereto, whether due to a breach of contract, breach of warranty, the negligence of Graco, or otherwise.

## **FOR GRACO CANADA CUSTOMERS**

The Parties acknowledge that they have required that the present document, as well as all documents, notices and legal proceedings entered into, given or instituted pursuant hereto or relating directly or indirectly hereto, be drawn up in English. Les parties reconnaissent avoir convenu que la rédaction du présente document sera en Anglais, ainsi que tous documents, avis et procédures judiciaires exécutés, donnés ou intentés, à la suite de ou en rapport, directement ou indirectement, avec les procédures concernées.

## Graco Information

For the latest information about Graco products, visit [www.graco.com](http://www.graco.com).

For patent information, see [www.graco.com/patents](http://www.graco.com/patents).

**TO PLACE AN ORDER, contact your Graco distributor or call to identify the nearest distributor.**

**Phone: 612-623-6921 or Toll Free: 1-800-328-0211 Fax: 612-378-3505**

*All written and visual data contained in this document reflects the latest product information available at the time of publication. Graco reserves the right to make changes at any time without notice.*

Original instructions. This manual contains English. MM 3A5646

**Graco Headquarters:** Minneapolis

**International Offices:** Belgium, China, Japan, Korea

**GRACO INC. AND SUBSIDIARIES • P.O. BOX 1441 • MINNEAPOLIS MN 55440-1441 • USA**  
**Copyright 2016, Graco Inc. All Graco manufacturing locations are registered to ISO 9001.**

[www.graco.com](http://www.graco.com)  
Revision A, February 2018